

Installation Instructions

WGA100 Wall Guard

Data Sheet: Page 1 of 2 CD/JM April 2017

1. Cut the aluminium retainer to the desired length, allowing 50mm clearance for each end cap and an additional 25mm clearance so that the end caps can be fitted and removed when placed near an architrave or wall. For internal corners, where closely positioned endcaps would reduce the clearance between them too much, it is necessary to reduce the retainer length a further 25mm.
2. Using a 6.0mm drill bit, drill holes in the aluminium retainer using the v-notch in the centre at 50mm from each end and spaced evenly between the end holes at a pitch of 9 anchor points per 4.00m length (i.e. approximately 500mm apart). Using the same 6mm drill bit, drill an additional hole 10mm from each end also along the v-notch to accommodate the bolt for end-caps where required.
3. Using an alignment laser, position the retainer against the wall at the desired height, aligning the v-notch on the centre-line of the retainer with the laser level. When positioning horizontally, allow for the end caps which need to be 25mm away from any hindering wall (50mm for internal corner). With the retainer in the desired position, mark the locations of the mounting holes on the wall with a marker. Drill all marked holes to the correct depth on the wall with a drill bit suitable for the screws and wall plug fixings being used (not supplied).
4. Before fitting the end caps, measure the length of the retainer and add 7mm which will be used as the cut length for the PVC-u cover. Joints in the PVC-u cover should ideally not coincide with joints in the retainer. Joints of the retainer and the PVC-u cover should be staggered and should be at least 300mm apart.
5. To secure the end-caps, put the washer on the bolt, push the bolt through the back of the retainer and fit the flanged nut.
6. Loosely attach the retainer to the wall using one screw at either end. Check alignment of all remaining holes in the retainer with the holes in the wall while maintaining alignment of centre-line of the retainer with the laser level. Correct any misaligned hole positions before fitting the end-caps.
7. Cut the PVC-u cover as per point 4, taking care to ensure that the cuts are both square and clean. Loosely position the cover on the aluminium retainer to check the fit length, adjusting if necessary. Hook the top edge of the cover over the top edge of the retainer while butting the cover up against one of the reveals. Press the base of the cover downwards towards the base of the aluminium retainer until it snaps into place. Approximately 300mm from the second reveal, fold the end of the profile inwards towards the reveal/end-cap so that there is a compressive force on the PVC-u cover against both end-caps/reveals to keep everything flush when the final section is snapped into place. If the length required is over 4 metres, clip one cover on entirely and then butt join subsequent cover pieces ensuring the ends are cut square to allow for a tight joint. To finish the run, follow the procedure above for fitting the final piece. The length of the PVC-u cover sections in any one run should be planned so that the final piece is not too short or close to the end cap both for aesthetics and ease of fitting. Wherever possible try and even out the lengths of the cover (i.e. for a 4.5 metre length consider using a 2m and a 2.5m length instead of a 4m & 0.5m length) whilst ensuring that joints are minimised and staggered (as per point 4).

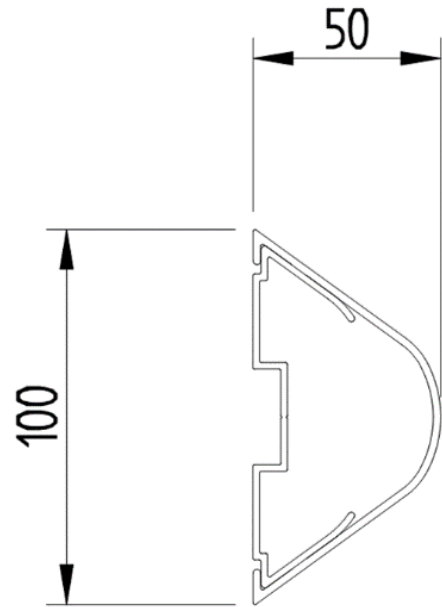

Fitters Tips:

- The PVC-u cover may try and compress under the pressure of the saw blade during the cutting process. This can be reduced by cutting very slowly.

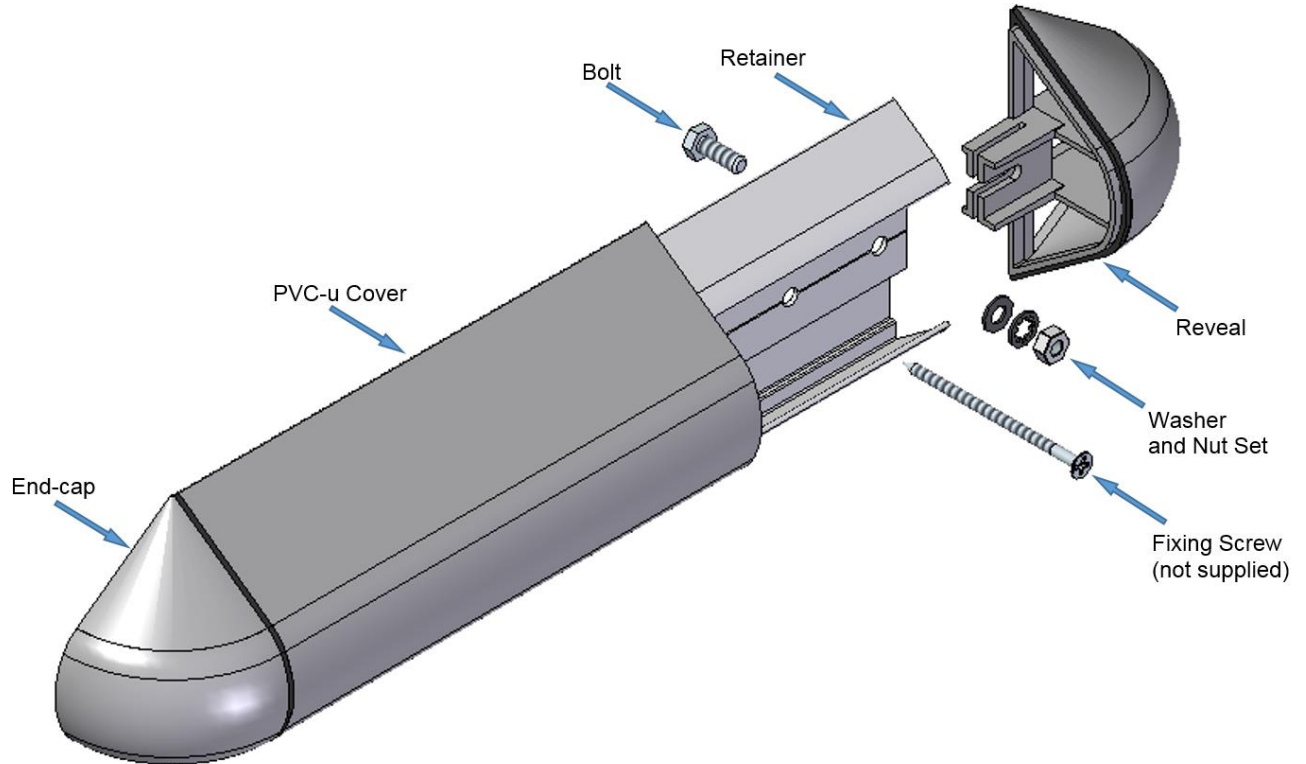

Part	Description
WGA1001/XXXK	End Cap (including reveal and fixings)
WGA100A	Aluminium Retainer
WGA100V/XXX	PVC-u Cover